



STU/D410S

N-Channel Logic Level Enhancement Mode Field Effect Transistor

PRODUCT SUMMARY		
V _{DS}	I _D	R _{DS(ON)} (mΩ) Max
40V	30A	20 @ V _{GS} = 10V
		30 @ V _{GS} = 4.5V

FEATURES

- Super high dense cell design for low R_{DS(ON)}.
- Rugged and reliable.
- Surface Mount Package.
- ESD Protected.

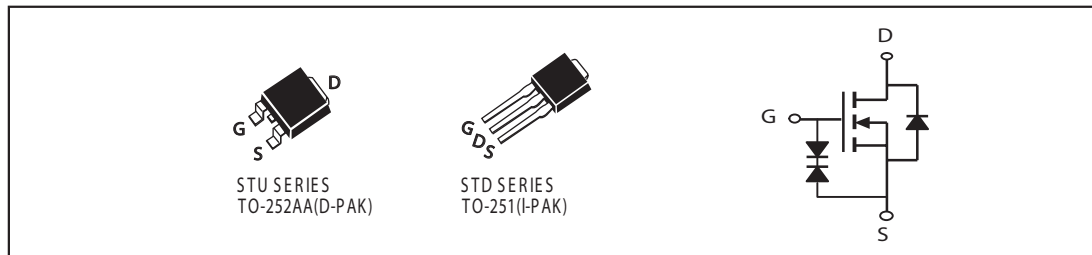

ABSOLUTE MAXIMUM RATINGS (T_A=25°C unless otherwise noted)

Parameter	Symbol	Limit	Unit
Drain-Source Voltage	V _{DS}	40	V
Gate-Source Voltage	V _{GS}	±20	V
Drain Current-Continuous ^a @ T _C =25°C -Pulsed ^b	I _D	30	A
	I _{DM}	100	A
Drain-Source Diode Forward Current	I _S	8	A
Maximum Power Dissipation @ T _C =25°C	P _D	50	W
Operating and Storage Temperature Range	T _J , T _{STG}	-55 to 175	°C

THERMAL CHARACTERISTICS

Thermal Resistance, Junction-to-Case	R _{θJC}	3	°C/W
Thermal Resistance, Junction-to-Ambient	R _{θJA}	50	°C/W

STU/D410S

ELECTRICAL CHARACTERISTICS (Tc=25 °C unless otherwise noted)

Parameter	Symbol	Condition	Min	Typ ^c	Max	Unit
OFF CHARACTERISTICS						
Drain-Source Breakdown Voltage	BV _{DSS}	V _{GS} =0V, I _D =250uA	40			V
Zero Gate Voltage Drain Current	I _{DSS}	V _{DS} =32V, V _{GS} =0V			1	uA
Gate-Body Leakage	I _{GSS}	V _{GS} =±20V, V _{DS} =0V			±10	uA
ON CHARACTERISTICS^a						
Gate Threshold Voltage	V _{GS(th)}	V _{DS} =V _{GS} , I _D =250uA	1	1.9	3	V
Drain-Source On-State Resistance	R _{DS(ON)}	V _{GS} =10V, I _D =10A		16	20	m ohm
		V _{GS} =4.5V, I _D =8A		23	30	m ohm
On-State Drain Current	I _{D(ON)}	V _{DS} =10V, V _{GS} =10V	30			A
Forward Transconductance	g _{FS}	V _{DS} =10V, I _D =10A		17		S
DYNAMIC CHARACTERISTICS^b						
Input Capacitance	C _{ISS}	V _{DS} =15V, V _{GS} =0V f=1.0MHz		690		pF
Output Capacitance	C _{OSS}			140		pF
Reverse Transfer Capacitance	C _{RSS}			95		pF
SWITCHING CHARACTERISTICS^b						
Turn-On Delay Time	t _{D(ON)}	V _{DD} =15V I _D =1A V _{GS} =10V R _{GEN} =3 ohm		13.1		ns
Rise Time	t _r			13.5		ns
Turn-Off Delay Time	t _{D(OFF)}			45.7		ns
Fall Time	t _f			11.8		ns
Total Gate Charge	Q _g	V _{DS} =20V, I _D =10A, V _{GS} =10V		13.5		nC
		V _{DS} =20V, I _D =10A, V _{GS} =4.5V		6.7		nC
Gate-Source Charge	Q _{gs}	V _{DS} =20V, I _D =10A V _{GS} =10V		1.65		nC
Gate-Drain Charge	Q _{gd}			3.85		nC

STU/D410S

ELECTRICAL CHARACTERISTICS ($T_c=25^\circ\text{C}$ unless otherwise noted)

Parameter	Symbol	Condition	Min	Typ	Max	Unit
DRAIN-SOURCE DIODE CHARACTERISTICS ^a						
Diode Forward Voltage	V_{SD}	$V_{GS} = 0V, I_s = 8A$		0.84	1.3	V

Notes

- a. Pulse Test: Pulse Width $\leq 300\mu\text{s}$, Duty Cycle $\leq 2\%$.
- b. Guaranteed by design, not subject to production testing.

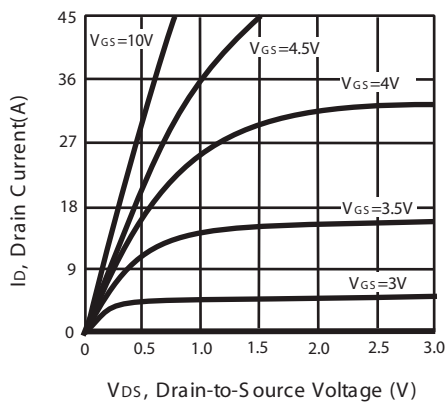

Figure 1. Output Characteristics

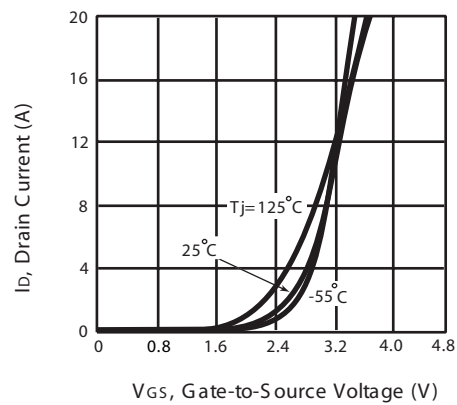

Figure 2. Transfer Characteristics

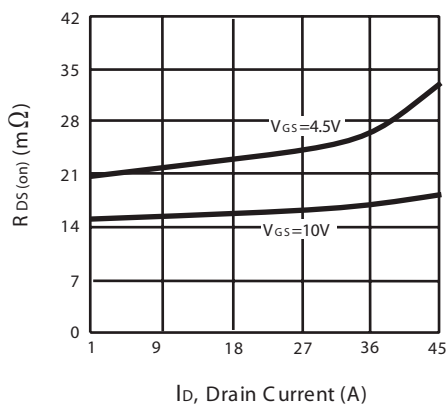

Figure 3. On-Resistance vs. Drain Current and Gate Voltage

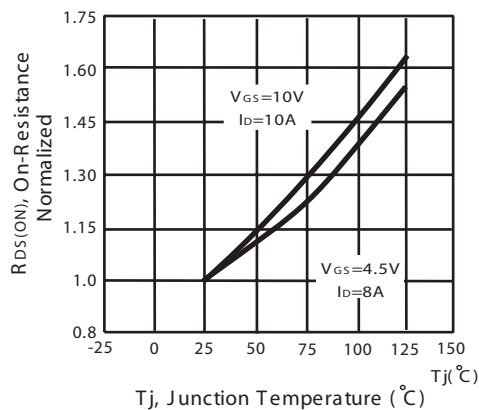

Figure 4. On-Resistance Variation with Drain Current and Temperature

STU/D410S

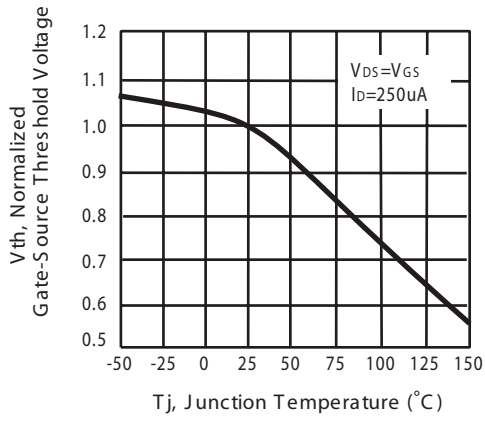

Figure 5. Gate Threshold Variation with Temperature

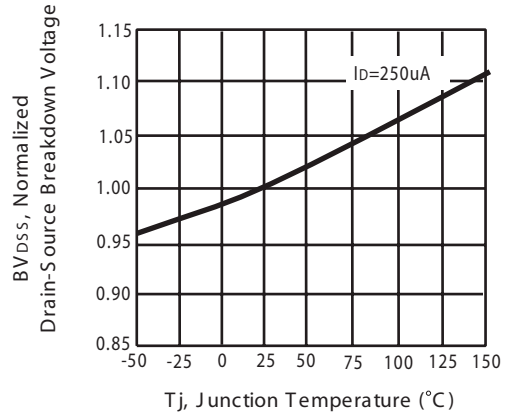

Figure 6. Breakdown Voltage Variation with Temperature

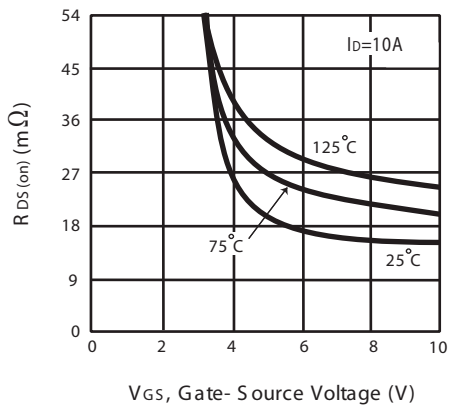

Figure 7. On-Resistance vs. Gate-Source Voltage

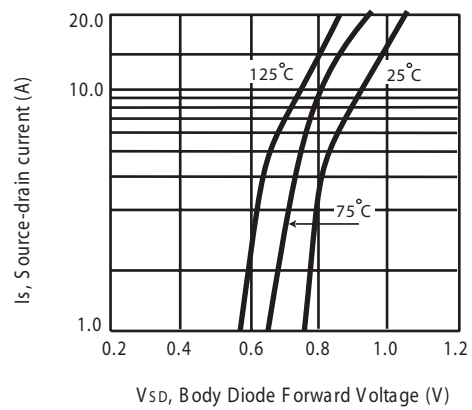

Figure 8. Body Diode Forward Voltage Variation with Source Current

STU/D410S

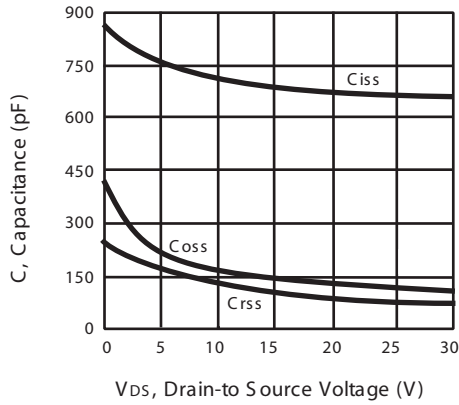

Figure 9. Capacitance

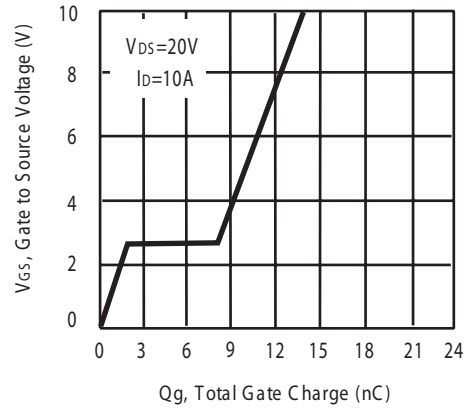

Figure 10. Gate Charge

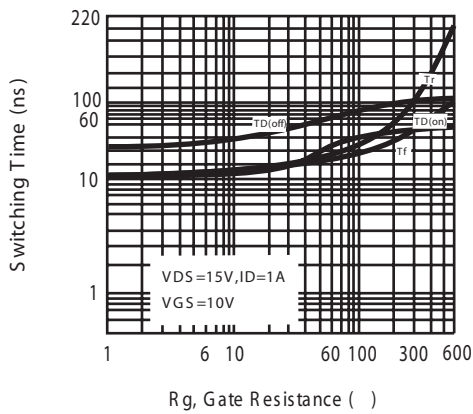

Figure 11. switching characteristics

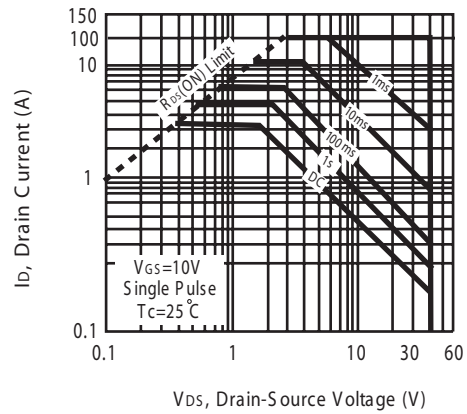

Figure 12. Maximum Safe Operating Area

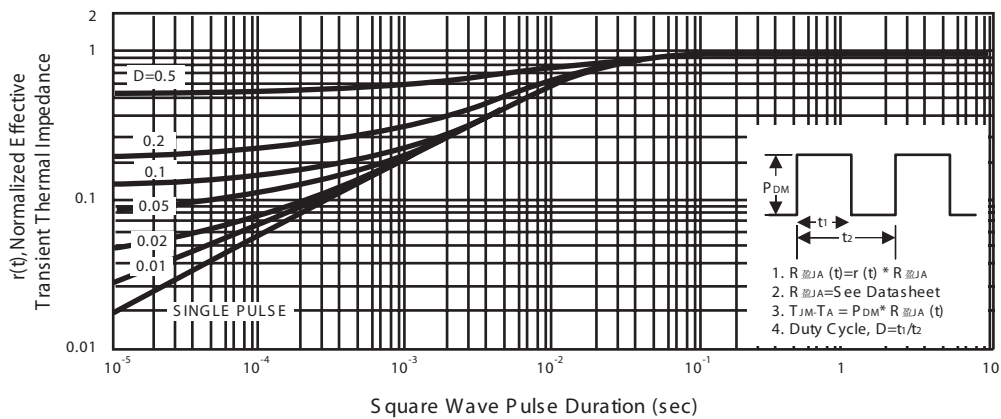
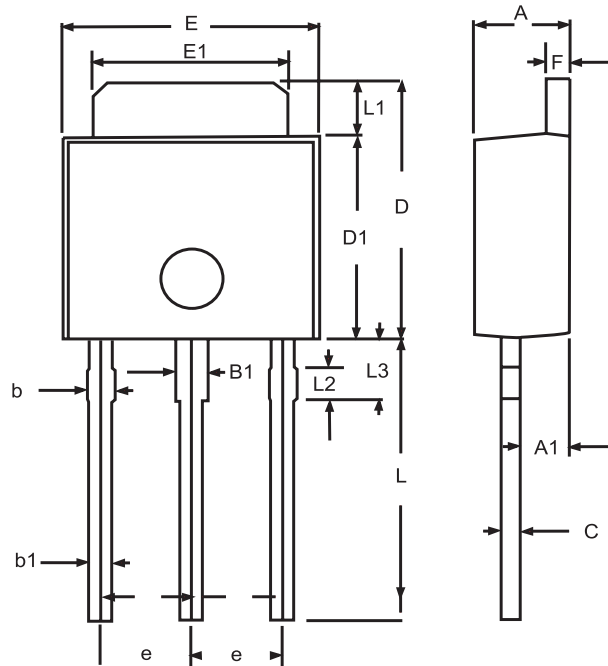

Figure 13. Normalized Thermal Transient Impedance Curve

STU/D410S

PACKAGE OUTLINE DIMENSIONS

TO-251



SYMBOLS	MILLIMETERS		INCHES	
	MIN	MAX	MIN	MAX
A	2.20	2.40	0.087	0.095
A1	1.100	1.300	0.043	0.051
B1	0.650	1.050	0.026	0.041
b	0.500	0.900	0.020	0.035
b1	0.400	0.800	0.016	0.32
C	0.400	0.600	0.016	0.024
D	6.700	7.300	0.264	0.287
D1	5.400	5.650	0.213	0.222
E	6.40	6.650	0.252	0.262
e	2.100	2.500	0.083	0.098
F	0.400	0.600	0.016	0.024
L	7.000	8.000	0.276	0.315
L1	1.300	1.700	0.051	0.067
L2	0.700	0.900	0.028	0.035
L3	1.400	1.800	0.055	0.071

STU/D410S

PACKAGE OUTLINE DIMENSIONS

TO-252

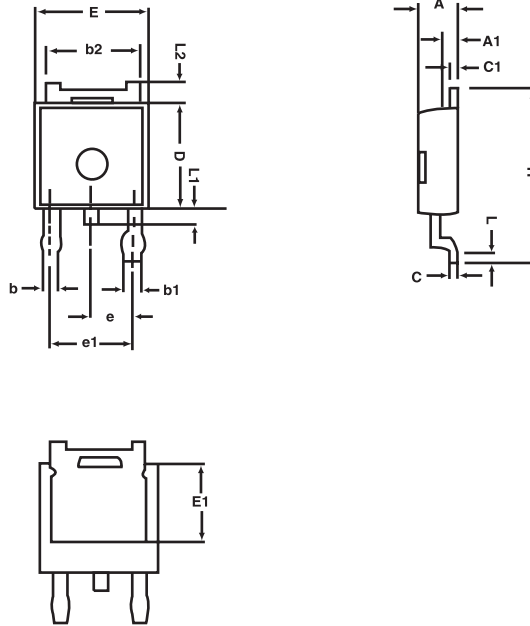

SYMBOLS	MILLIMETERS		INCHES	
	MIN	MAX	MIN	MAX
A	2.25	2.35	0.089	0.093
A1	0.95	1.05	0.037	0.041
b	0.77	0.85	0.030	0.033
b1	0.84	0.94	0.033	0.037
b2	5.30	5.45	0.209	0.215
C	0.49	0.53	0.019	0.021
D	6.00	6.20	0.236	0.244
E	6.40	6.60	0.252	0.260
E1	3.18	3.67	0.125	0.145
e	2.29	BSC	0.090	BSC
H	9.70	10.10	0.382	0.398
L	1.425	1.625	0.056	0.064
L1	0.650	0.850	0.026	0.033
L2	0.600	REF .	0.024	REF .

STU/D410S

TO-252 Tape and Reel Data

TO-252 Carrier Tape

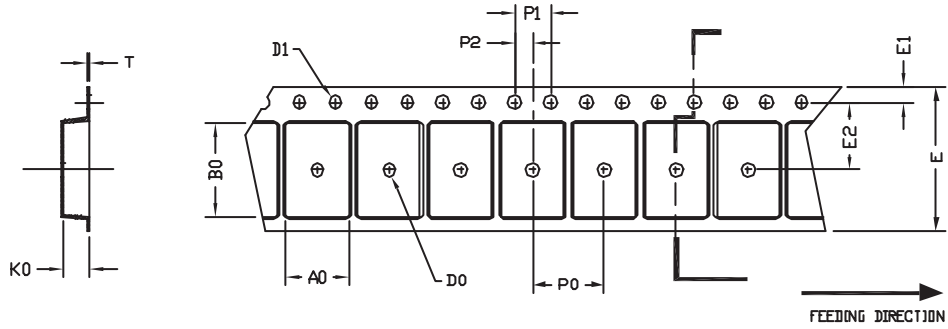

UNIT: b

PACKAGE	A0	B0	K0	D0	D1	E	E 1	E 2	P0	P1	P2	T
TO-252 (16 b I)	6.80 0.1	10.3 0.1	2.50 0.1	榎2	榎1.5 +0.1 -0	16.0 0.3	1.75 0.1	7.5 0.15	8.0 0.1	4.0 0.1	2.0 0.15	0.3 0.05

TO-252 Reel

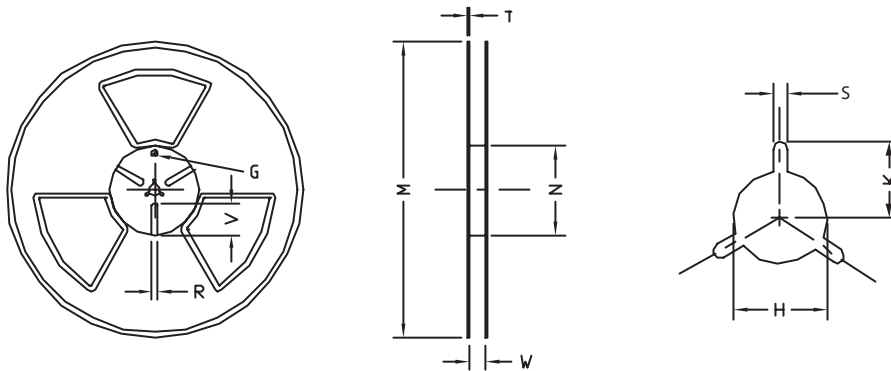

UNIT: b

TAPE SIZE	REEL SIZE	M	N	W	T	H	K	S	G	R	V
16 b	榎 330	榎330 0.5	榎97 1.0	17.0 +1.5 -0	2.2	榎13.0 +0.5 -0.2	10.6	2.0 0.5	---	---	---