



三合微科股份有限公司
SAMHOP Microelectronics Corp.

SM5038RF

2¹² RF DECODER

REV. 1.11

APRIL 12, 2004

**The information in this document is subject to change without notice.
© SAMHOP Microelectronics Corp. All Rights Reserved.**

台北縣新店市民權路100號7樓
7F, No. 100, Min-Chyuan Road, Hsintien, Taipei Hsien, Taiwan, R.O.C.
TEL: 886-2-2218-3978/2820 FAX: 886-2-2218-3320
Email : info@samhop.com.tw



2¹² RF DECODER

DESCRIPTION

SM5038RF is a remote control decoder paired with SM5028RF utilizing CMOS Technology. It has 12-bit 2-state address pins providing a 2¹² address codes; thereby, drastically reducing any code collision and unauthorized code scanning possibilities. SM5038RF is available in several options to suitable every application needs : variable number of data output pins, latch or momentary output type.

FEATURES

- * CMOS Technology
- * Low Power Consumption
- * Very High Noise Immunity
- * Up to 12 2-State Code Address Pins
- * Wide Range of Operating Voltage:
- * Vcc = 3 ~ 12 Volts
- * Single Resistor Oscillator
- * Available in DIP and SOP Package

APPLICATIONS

- * Car Security
- * Garage Door
- * Home Security/Automation System
- * Toys
- * Remote Control for Industrial Use

PIN CONFIGURATION (DIP)

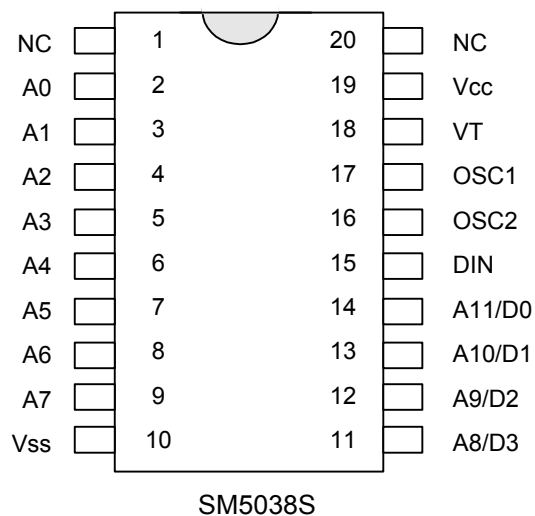
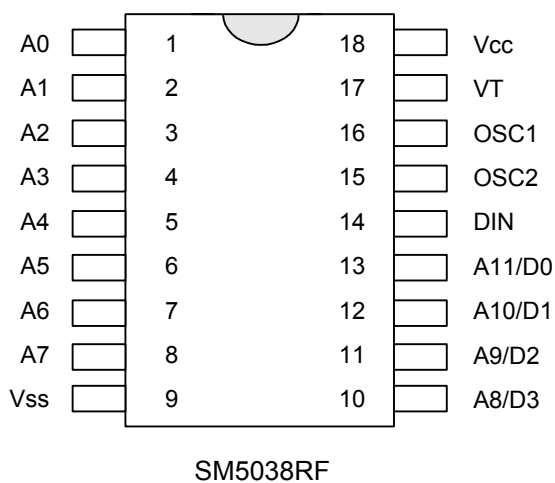



2¹² RF DECODER

BLOCK DIAGRAM

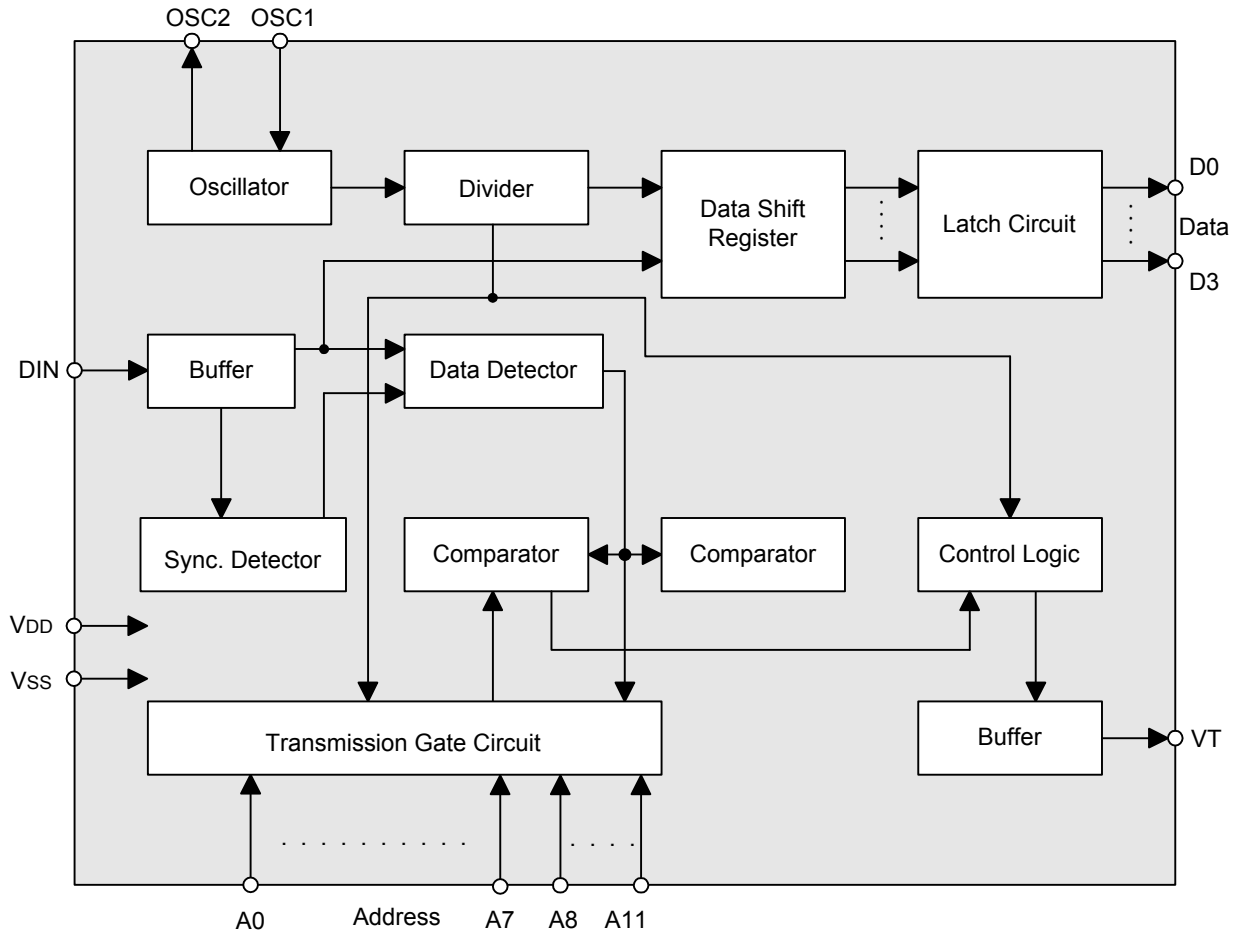

**2¹² RF DECODER****PIN DESCRIPTION**

NO.	PIN NAME	I / O	FUNCTION
1	A0	I	Address input , each pin can be set to "0" , "1".
2	A1	I	
3	A2	I	
4	A3	I	
5	A4	I	
6	A5	I	
7	A6	I	
8	A7	I	
9	V _{SS}	POWER	Negative power supply.
10	A8/D3	I/O	Address input/ Data output active high.
11	A9/D2	I/O	
12	A10/D1	I/O	
13	A11/D0	I/O	
14	DIN	I	Receive from RF module.
15	OSC2	O	Resistor connected between these two pins determine the system clock.
16	OSC1	I	
17	VT	O	Valid transmission indication.
18	V _{DD}	POWER	Positive power supply.



2¹² RF DECODER

Decoder with Data Output Pins

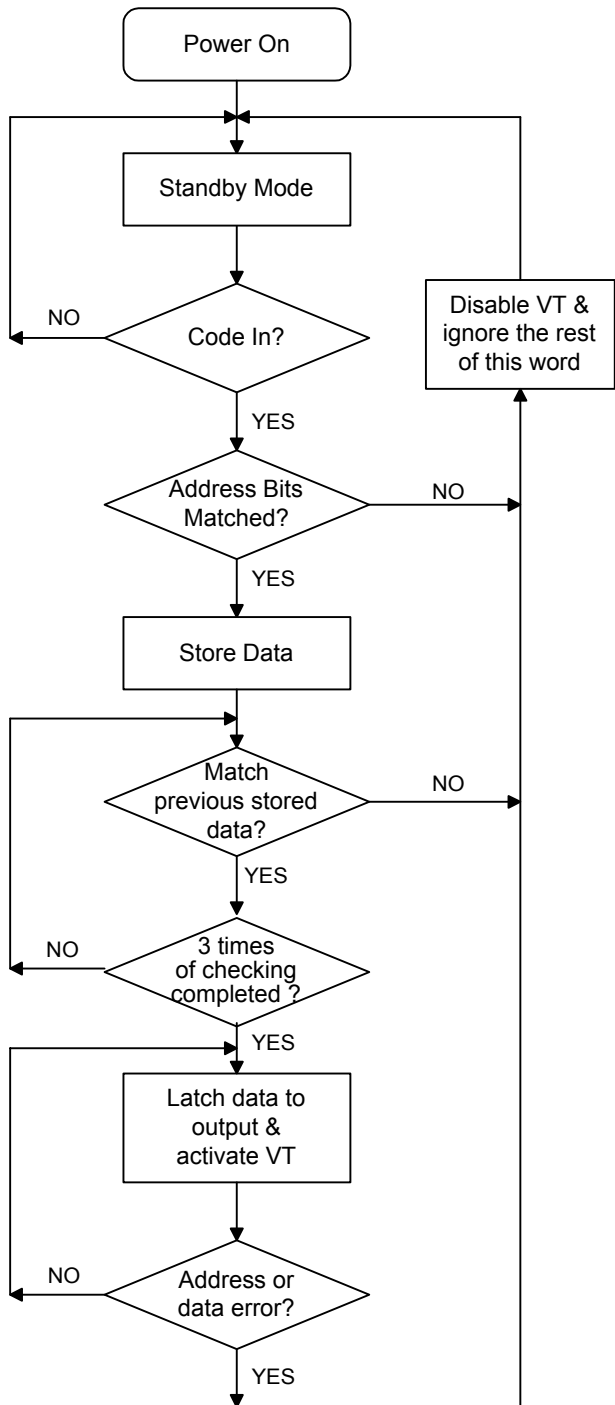

After Power On SM5038RF is set in Address search mode, if SM5038RF finds 3 consecutive Address that matches the Address setting of SM5038RF. SM5038RF will enter Data Compare mode. It will compare perviously 3 received data, if they match then SM5038RF will set VT high and send data O/P.



2¹² RF DECODER

Single Resistor Oscillator

SM5038RF's oscillator can be constructed by connecting a resistor between OSC1 and OSC2 pin.

Decoder OSC Frequency

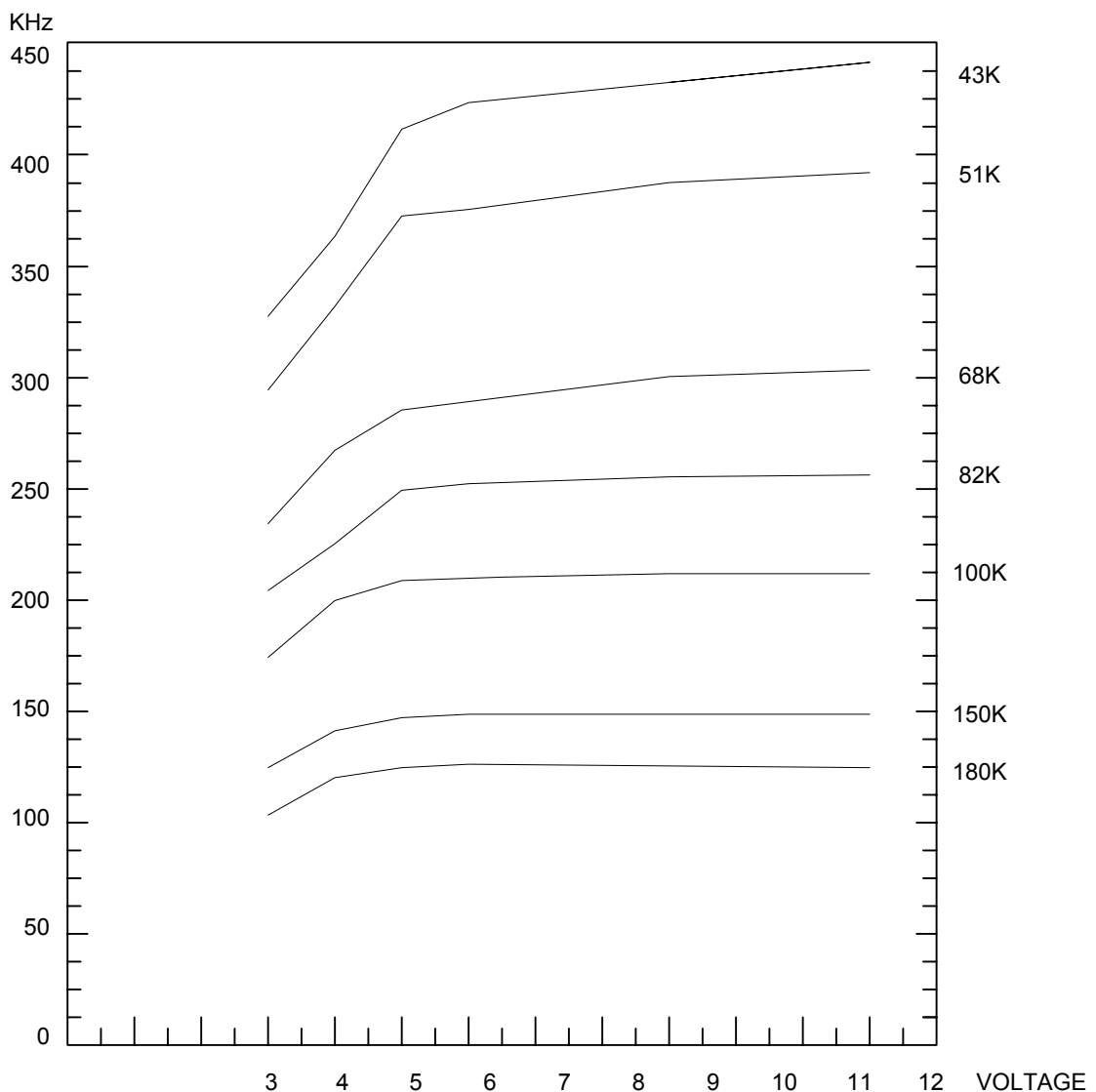

The recommended oscillator frequency is F_{oscD} (SM5038RF decoder) \approx 8~10 F_{oscD} (SM5028RF encoder)

**2¹² RF DECODER****ABSOLUTE MAXIMUM RATINGS**

Parameter	Symbol	Conditions	Ratings	Unit
Supply Voltage	$V_I - V_{SS}$		-0.3~13	V
Input Voltage	$V_{SS} - V_{DD}$		$V_{SS}-0.3\sim V_{DD}+0.3$	V
Operating Temperature	T_{opr}		-20~75	°C
Storage Temperature	T_{stg}	$V_{DD} - V_{SS} = 12V$	-50~125	°C

DC ELECTRICAL CHARACTERISTICS

(Ta=25 °C)

PARAMETER	SYMBOL	CONDITIONS	LIMIT			UNIT
			MIN.	TYP.	MAX.	
Operating Voltage	V_{DD}		2.4	5	12	V
Standby Current	I_{STB}	$V_{DD}=5V$ OSC stop	-	0.1	1	μA
		$V_{DD}=12V$ OSC stop	-	2	4	μA
Operating Current	I_{DD}	$V_{DD}=5V$ No load $F_{osc}=150kHz$	-	200	400	μA
Data Output Source Current (D8~D11)	I_O	$V_{DD}=5V$ $V_{OH}=4.5V$	-1	-1.6	-	mA
Data Output Sink Current (D8~D11)	I_O	$V_{DD}=5V$ $V_{OL}=0.5V$	1	1.6	-	mA
VT Output Source Current	I_{VT}	$V_{DD}=5V$ $V_{OH}=4.5V$	-1	-1.6	-	mA
VT Output Sink Current		$V_{DD}=5V$ $V_{OL}=0.5V$	1	1.6	-	mA
"H" Input Voltage	V_{IH}	- ($V_{DD}=5V$)	3.5	-	5	V
"L" Input Voltage	V_{IL}	- ($V_{DD}=5V$)	0	-	1	V
Oscillator Frequency	F_{OSC}	$V_{DD}=5V$ $R_{OSC}=150k\Omega$	-	150	-	kHz



2¹² RF DECODER

APPLICATION CIRCUIT

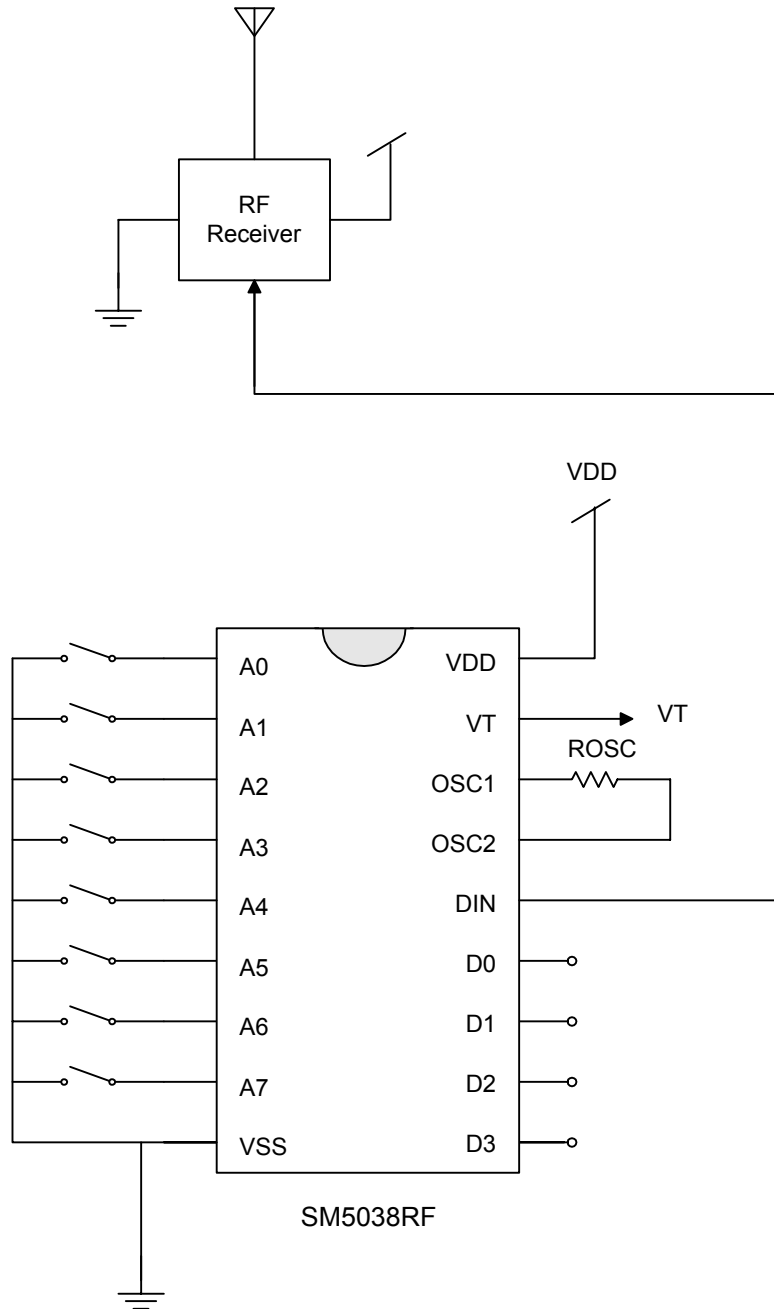



2¹² RF DECODER

ORDERING INFORMATION

Part NO.	Package
SM5038RF	18Pin DIP

Part NO.	Package
SM5038S	20Pin SOP

