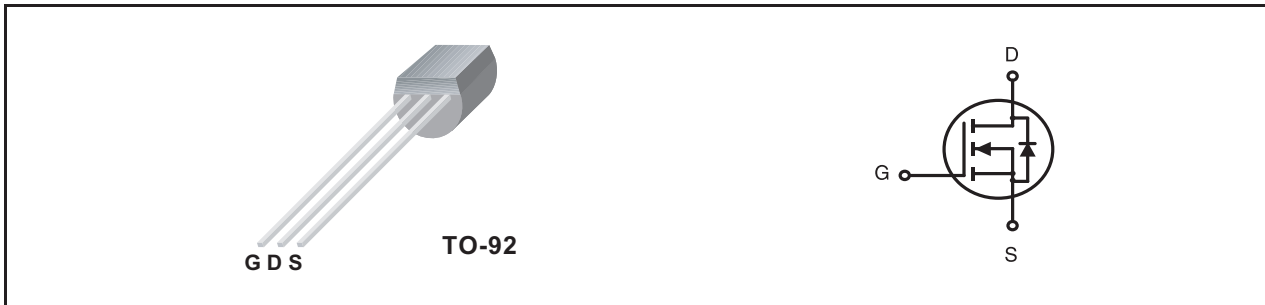

**500V N-Channel Planar MOSFET****PRODUCT SUMMARY**

V _{DSS}	I _D	R _{DS(ON)} (mΩ) Max
500V	0.4A	5.6 @ V _{GS} =10V, I _D =0.2A

FEATURES

- Fast Switching.
- 100% Avalanche Rated.

**ABSOLUTE MAXIMUM RATINGS (T_A=25°C unless otherwise noted)**

Symbol	Parameter	Max.	Units
V _{DSS}	Drain-Source Voltage	500	V
V _{GS}	Gate-Source Voltage	±30	V
I _D	Continuous Drain Current	T _C =25°C	0.4
		T _C =100°C	0.25
I _{DM}	Pulsed Drain Current, V _{GS} =10V ^a	2	A
E _{AS}	Single Pulse Avalanche Energy ^b	40	mJ
dv/dt	Peak Diode Recovery Energy ^c	4.5	V/ns
P _D	Power Dissipation	T _C =25°C	2.08
	Linear Derating Factor	T _C >25°C	0.017
T _J , T _{STG}	Operating and Storage Temperature Range	-55 to 150	°C

THERMAL CHARACTERISTICS

R _{θ JC}	Thermal Resistance, Junction-to-Case	60	°C/W
R _{θ JA}	Thermal Resistance, Junction-to-Ambient	140	°C/W

SDY01N50

Preliminary

ELECTRICAL CHARACTERISTICS (T_A=25°C unless otherwise noted)

Symbol	Parameter	Conditions	Min	Typ	Max	Units
OFF CHARACTERISTICS						
V _{(BR)DSS}	Drain-Source Breakdown Voltage	V _{GS} =0V, I _D =250μA	500			V
ΔV _{(BR)DSS} / ΔT _J	Breakdown Voltage Temperature Coefficient	Reference to 25°C, I _D =250μA		0.5		V/°C
I _{DSS}	Drain-to-Source Leakage Current	V _{DS} =500V, V _{GS} =0V			20	μA
I _{GSSF}	Gate-Body Leakage Current, Forward	V _{DS} =0V, V _{GS} =30V			100	nA
I _{GSSR}	Gate-Body Leakage Current, Reverse	V _{DS} =0V, V _{GS} =-30V			-100	nA
ON CHARACTERISTICS						
V _{GS(th)}	Gate Threshold Voltage	V _{DS} =V _{GS} , I _D =250μA	2.0		4.0	V
R _{DS(on)}	Static Drain-Source On-Resistance	V _{GS} =10V, I _D =0.2A ^d			5.6	ohm
g _{FS}	Forward Transconductance	V _{DS} =15V, I _D =0.2A ^d			10	S
DYNAMIC CHARACTERISTICS						
C _{ISS}	Input Capacitance	V _{DS} =25V, V _{GS} =0V f=1.0MHz		150		pF
C _{OSS}	Output Capacitance			28		pF
C _{RSS}	Reverse Transfer Capacitance			4.1		pF
SWITCHING CHARACTERISTICS						
t _{D(on)}	Turn-On Delay Time	V _{DD} =250V I _D =1A R _G =10 ohm, R _D =280 ohm V _{GS} =10V ^d		10		ns
t _r	Turn-On Rise Time			10		ns
t _{D(off)}	Turn-Off Delay Time			20		ns
t _f	Turn-Off Fall Time			15		ns
Q _g	Total Gate Charge	V _{DS} =250V, I _D =1A, V _{GS} =10V ^d		4.9		nC
Q _{gs}	Gate-Source Charge			0.66		nC
Q _{gd}	Gate-Drain("Miller") Charge			2.9		nC
DRAIN-SOURCE DIODE CHARACTERISTICS AND MAXIMUM RATINGS						
I _S	Maximum Continuous Source Current(Body Diode)				0.4	A
I _{SM}	Maximum Pulsed Source Current(Body Diode)				2	A
V _{SD}	Drain-Source Diode Forward Voltage	V _{GS} =0V, I _S =0.4A ^d			1.5	V
Notes :						
a. Repetitive Rating : Pulse width limited by maximum junction temperature.						
b. V _{DD} =50V, starting T _J =25°C, L=80mH, R _G =25Ω, I _{AS} =1A						
c. I _{SD} ≤ 1.2A, di/dt ≤ 100A/μs, V _{DD} ≤ V _{(BR)DSS} , T _J ≤ 150°C						
d. Pulse Test : Pulse width ≤ 300μs, Duty cycle ≤ 2%.						

Jul,22,2009

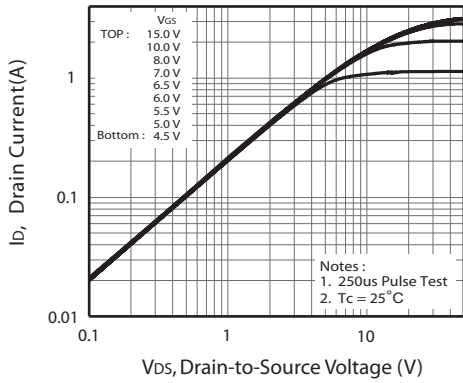

Figure 1. Output Characteristics

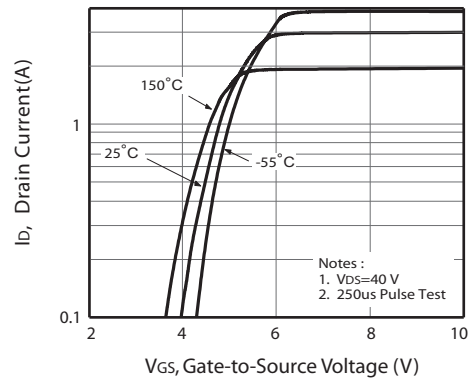

Figure 2. Transfer Characteristics

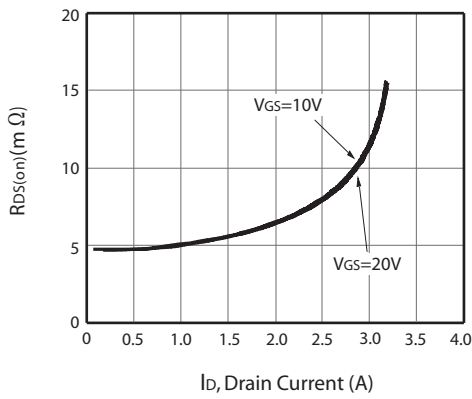

Figure 3. On-Resistance vs. Drain Current and Gate Voltage

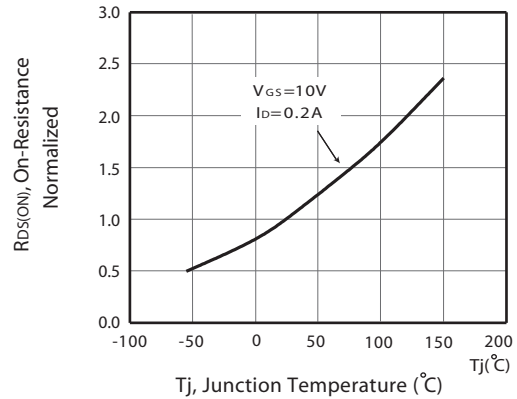

Figure 4. On-Resistance Variation with Drain Current and Temperature

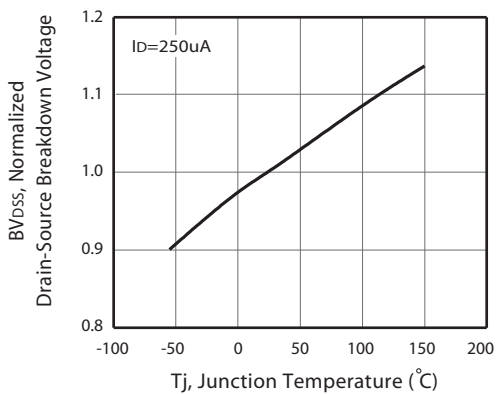

Figure 5. Breakdown Voltage Variation with Temperature

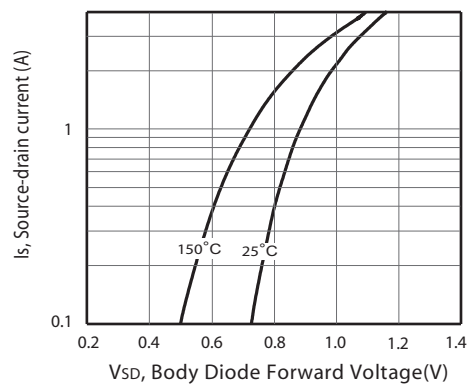
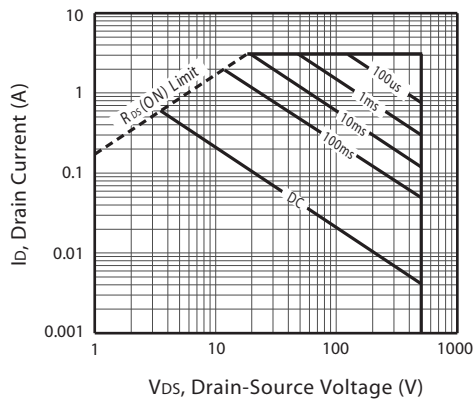
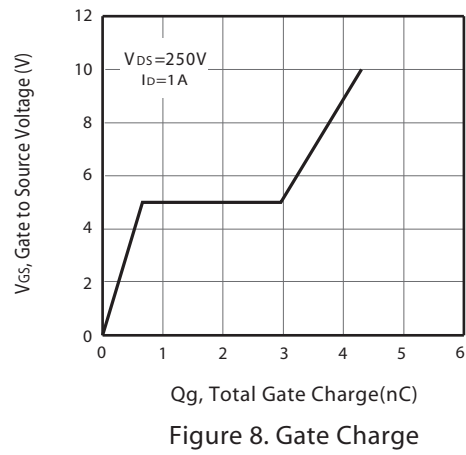
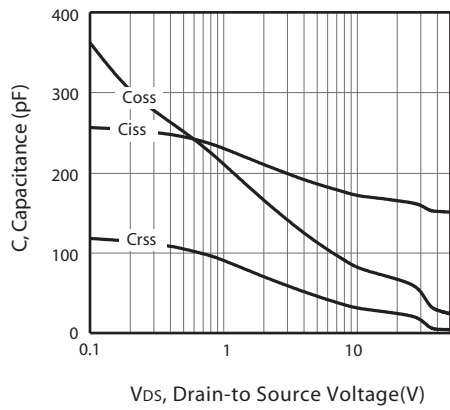

Figure 6. Body Diode Forward Voltage Variation with Source Current

SDY01N50

Preliminary



Jul,22,2009

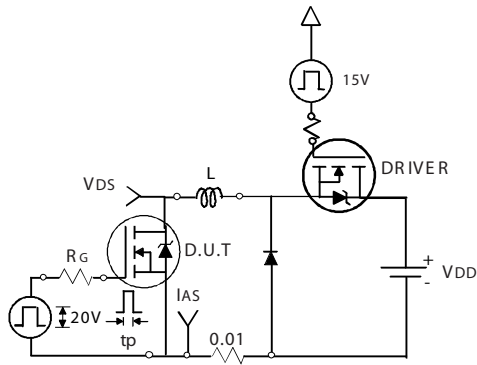

Unclamped Inductive Test Circuit

Figure 10a.

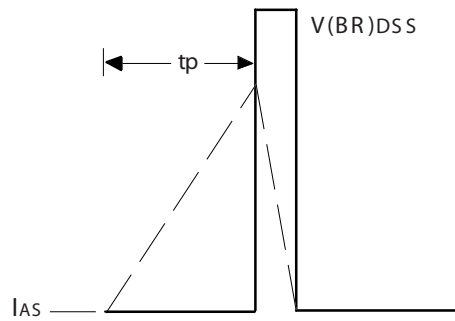

Unclamped Inductive Waveforms

Figure 10b.

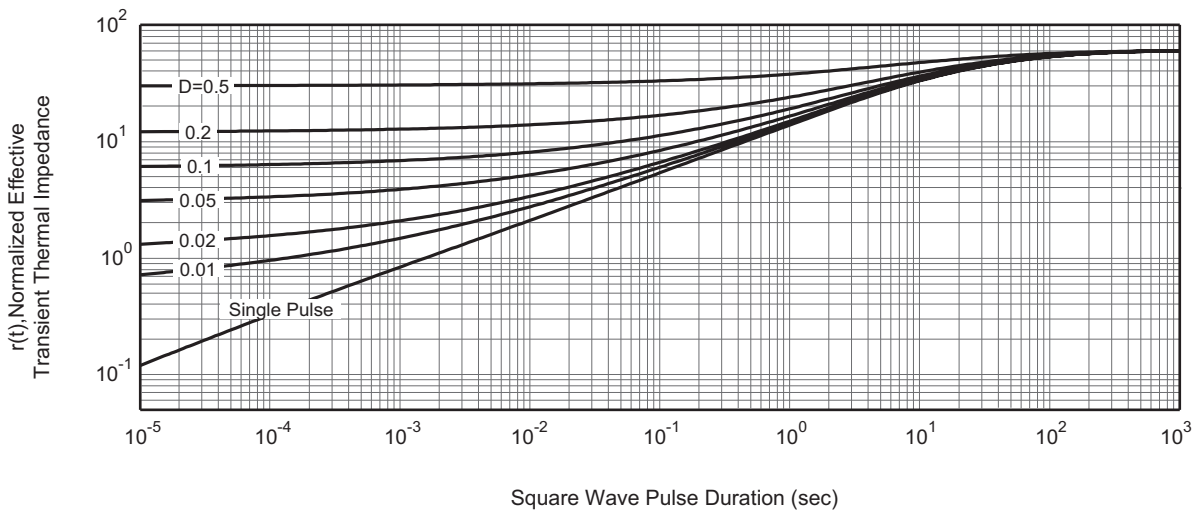

Figure 11 Normalized Thermal Transient Impedance Curve

SDY01N50

Preliminary

PACKAGE OUTLINE DIMENSIONS

TO-92

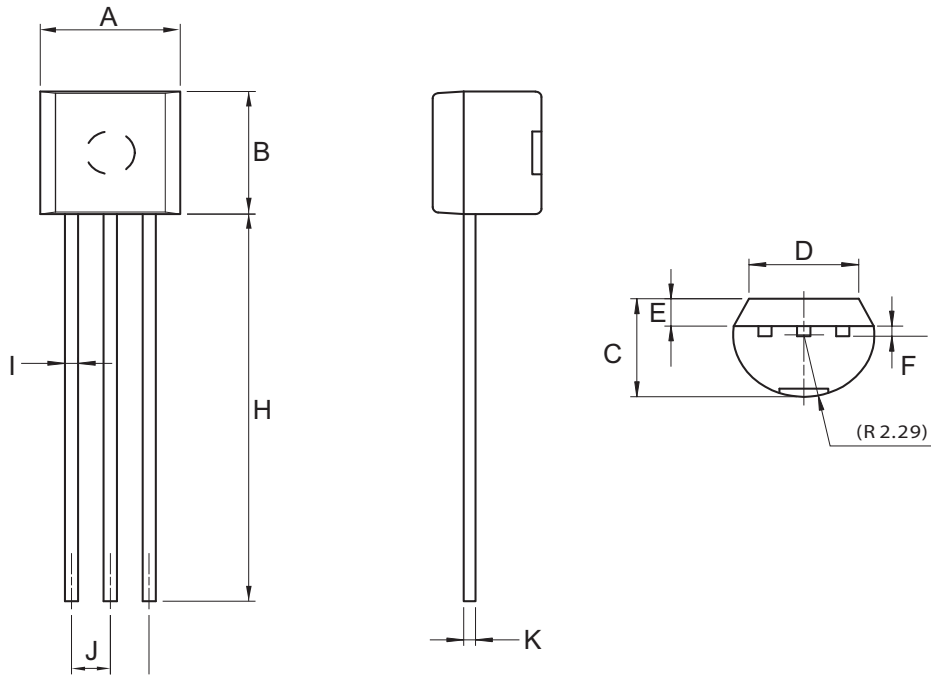

SYMBOLS	MILLIMETERS		INCHES	
	MIN	MAX	MIN	MAX
A	4.43	4.83	0.174	0.190
B	4.38	4.78	0.172	0.188
C	---	3.86	---	0.152
D	3.40	3.80	0.134	0.150
E	0.92	1.12	0.036	0.044
F	0.33	0.43	0.013	0.017
H	14.07	14.87	0.554	0.585
I	0.36	0.56	0.014	0.022
J	1.07	1.47	0.042	0.058
K	0.33	0.48	0.013	0.019

Jul,22,2009