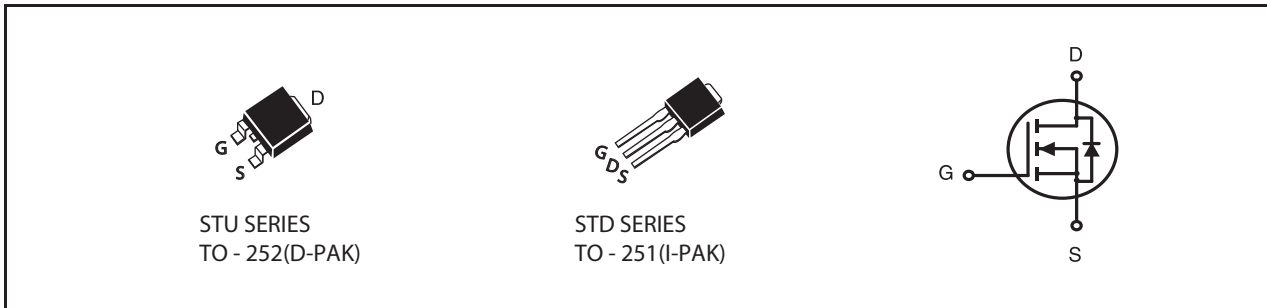

**600V N-Channel Planar MOSFET****PRODUCT SUMMARY**

V _{DSS}	I _D	R _{DS(ON)} (mΩ) Max
600V	2A	4.4 @ V _{GS} =10V, I _D =1A

FEATURES

- Low Cr_{ss} (typical 3pF).
- Fast Switching.
- 100% Avalanche Rated.

**ABSOLUTE MAXIMUM RATINGS** (T_A=25°C unless otherwise noted)

Symbol	Parameter	Max.	Units
V _{DSS}	Drain-Source Voltage	600	V
V _{GS}	Gate-Source Voltage	±30	V
I _D	Continuous Drain Current	T _C =25°C	2
		T _C =100°C	1.2
I _{DM}	Pulsed Drain Current, V _{GS} =10V ^a	8	A
E _{AS}	Single Pulse Avalanche Energy ^b	106	mJ
dv/dt	Peak Diode Recovery Energy ^c	4.5	V/ns
P _D	Power Dissipation	T _C =25°C	42
	Linear Derating Factor	T _C >25°C	0.33
T _J , T _{STG}	Operating and Storage Temperature Range	-55 to 150	°C

THERMAL CHARACTERISTICS

R _{θJC}	Thermal Resistance, Junction-to-Case	3	°C/W
R _{θJA}	Thermal Resistance, Junction-to-Ambient	50	°C/W

SDU/D02N60A

Preliminary

ELECTRICAL CHARACTERISTICS (T_A=25°C unless otherwise noted)

Symbol	Parameter	Conditions	Min	Typ	Max	Units
OFF CHARACTERISTICS						
V _{(BR)DSS}	Drain-Source Breakdown Voltage	V _{GS} =0V, I _D =250uA	600			V
ΔV _{(BR)DSS} / ΔT _J	Breakdown Voltage Temperature Coefficient	Reference to 25°C, I _D =250uA		TBD		V/°C
I _{DSS}	Drain-to-Source Leakage Current	V _{DS} =600V, V _{GS} =0V			20	uA
I _{GSSF}	Gate-Body Leakage Current, Forward	V _{DS} =0V, V _{GS} =30V			100	nA
I _{GSSR}	Gate-Body Leakage Current, Reverse	V _{DS} =0V, V _{GS} =-30V			-100	nA
ON CHARACTERISTICS						
V _{GS(th)}	Gate Threshold Voltage	V _{DS} =V _{GS} , I _D =250uA	2.0		4.0	V
R _{DS(ON)}	Static Drain-Source On-Resistance	V _{GS} =10V, I _D =1A ^d			4.4	ohm
g _{FS}	Forward Transconductance	V _{DS} =15V, I _D =1A ^d			10	S
DYNAMIC CHARACTERISTICS						
C _{ISS}	Input Capacitance	V _{DS} =25V, V _{GS} =0V f=1.0MHz		240		pF
C _{OSS}	Output Capacitance			35		pF
C _{RSS}	Reverse Transfer Capacitance			3		pF
SWITCHING CHARACTERISTICS						
t _{D(ON)}	Turn-On Delay Time	V _{DD} =300V I _D =2A R _G =10 ohm, R _D =150 ohm V _{GS} =10V ^d		13		ns
t _r	Turn-On Rise Time			38		ns
t _{D(OFF)}	Turn-Off Delay Time			24		ns
t _f	Turn-Off Fall Time			51		ns
Q _g	Total Gate Charge	V _{DS} =300V, I _D =2A, V _{GS} =10V ^d		8.8		nC
Q _{gs}	Gate-Source Charge			12.1		nC
Q _{gd}	Gate-Drain("Miller") Charge			5.1		nC
DRAIN-SOURCE DIODE CHARACTERISTICS AND MAXIMUM RATINGS						
I _S	Maximum Continuous Source Current(Body Diode)				2	A
I _{SM}	Maximum Pulsed Source Current(Body Diode)				8	A
V _{SD}	Drain-Source Diode Forward Voltage	V _{GS} =0V, I _S =1A ^d			1.5	V
Notes :						
a. Repetitive Rating : Pulse width limited by maximum junction temperature.						
b. V _{DD} =50V, starting T _J =25°C, L=53mH, R _G =25Ω, I _{AS} =2A						
c. I _{SD} ≤ 2A, di/dt ≤ 100A/us, V _{DD} ≤ V _{(BR)DSS} , T _J ≤ 150°C						
d. Pulse Test : Pulse width ≤ 300us, Duty cycle ≤ 2%.						

Jul,22,2009

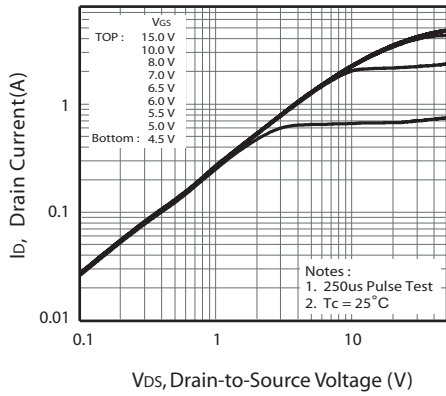

Figure 1. Output Characteristics

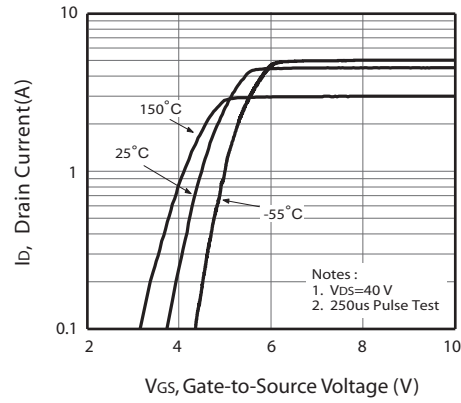

Figure 2. Transfer Characteristics

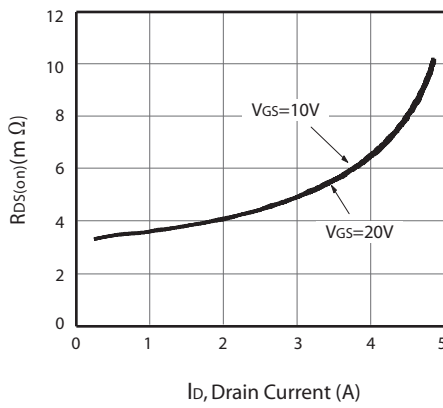

Figure 3. On-Resistance vs. Drain Current and Gate Voltage

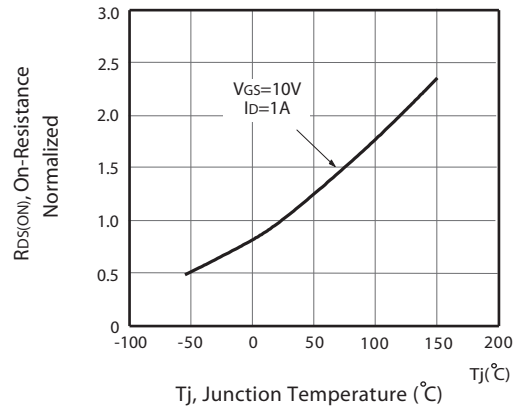

Figure 4. On-Resistance Variation with Drain Current and Temperature

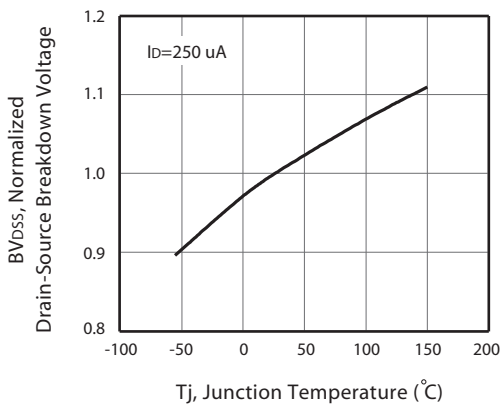

Figure 5. Breakdown Voltage Variation with Temperature

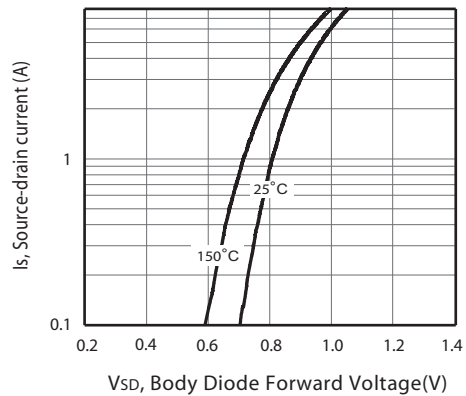

Figure 6. Body Diode Forward Voltage Variation with Source Current

SDU/D02N60A

Preliminary

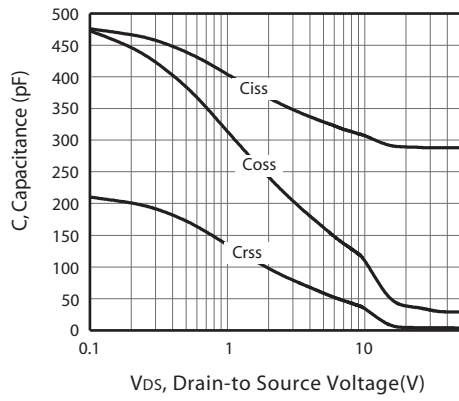

Figure 7. Capacitance

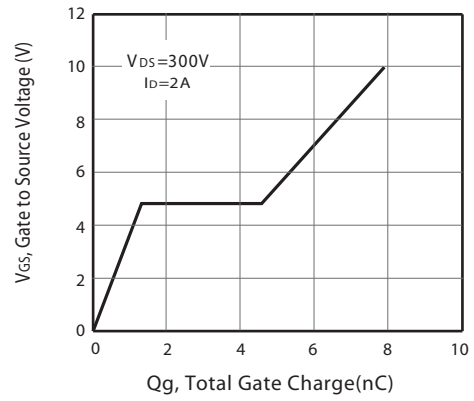

Figure 8. Gate Charge

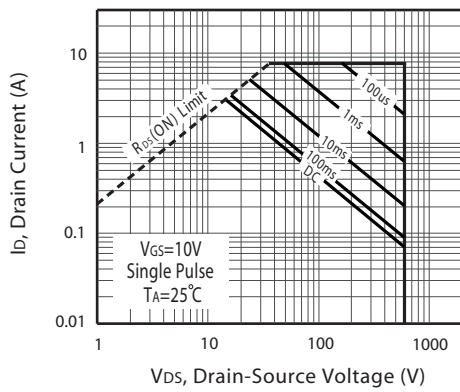
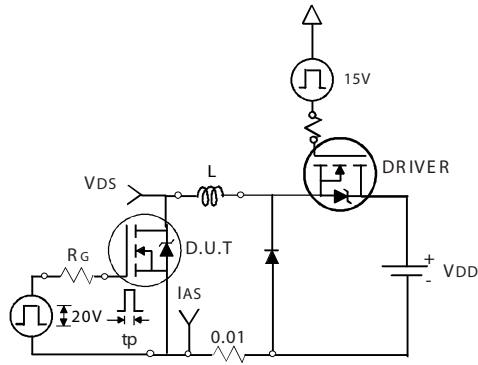

Figure 9. Maximum Safe Operating Area

Jul,22,2009

SDU/D02N60A

Preliminary



Unclamped Inductive Test Circuit

Figure 10a.

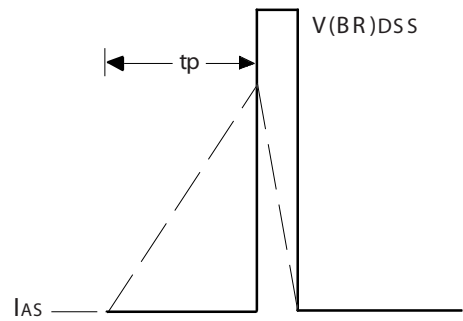

Unclamped Inductive Waveforms

Figure 10b.

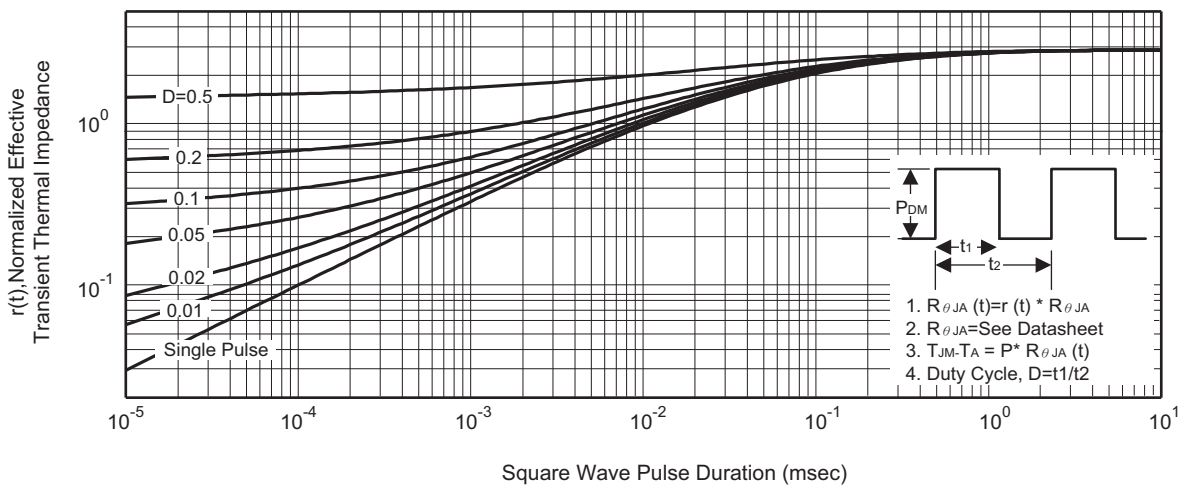

Figure 11. Normalized Thermal Transient Impedance Curve

Jul,22,2009

SDU/D02N60A

Preliminary

PACKAGE OUTLINE DIMENSIONS

TO-251

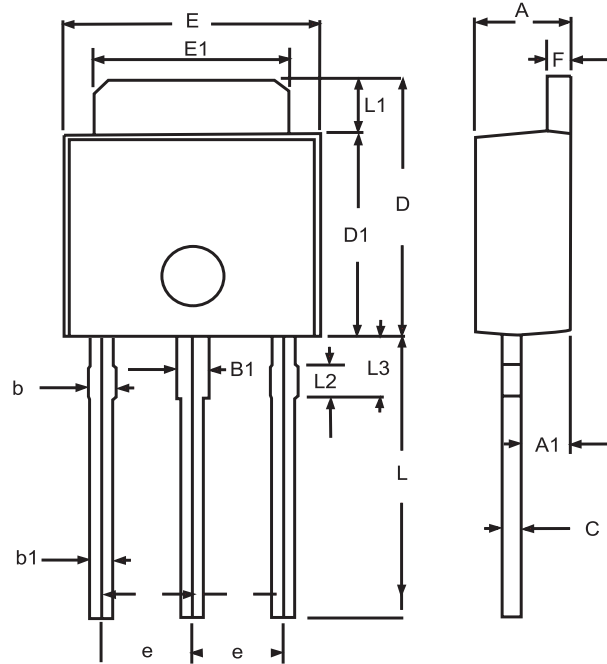

SYMBOLS	MILLIMETERS		INCHES	
	MIN	MAX	MIN	MAX
A	2.20	2.40	0.087	0.095
A1	1.100	1.300	0.043	0.051
B1	0.650	1.050	0.026	0.041
b	0.500	0.900	0.020	0.035
b1	0.400	0.800	0.016	0.32
C	0.400	0.600	0.016	0.024
D	6.700	7.300	0.264	0.287
D1	5.400	5.650	0.213	0.222
E	6.40	6.650	0.252	0.262
e	2.100	2.500	0.083	0.098
F	0.400	0.600	0.016	0.024
L	7.000	8.000	0.276	0.315
L1	1.300	1.700	0.051	0.067
L2	0.700	0.900	0.028	0.035
L3	1.400	1.800	0.055	0.071

Jul,22,2009

SDU/D02N60A

Preliminary

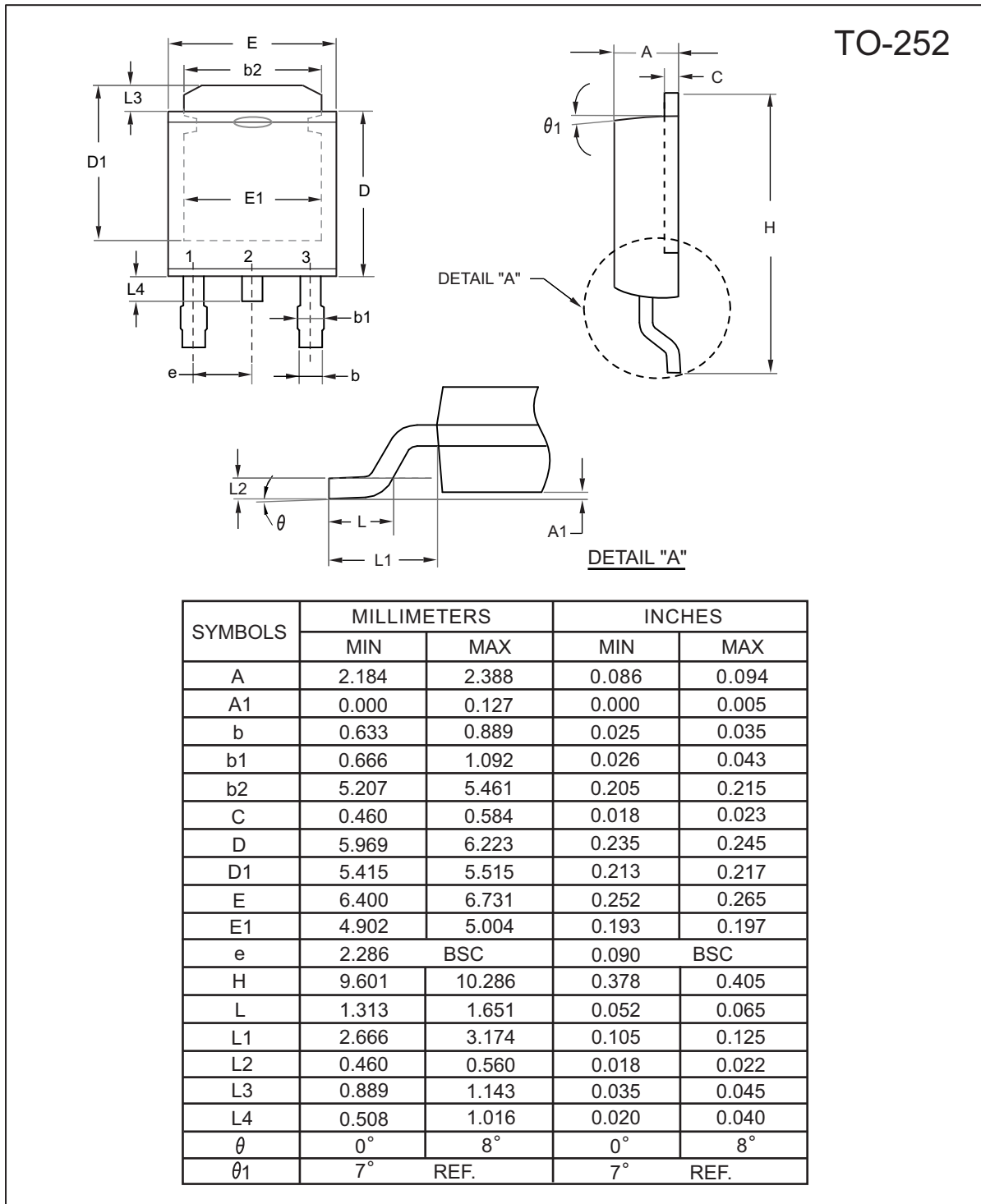

Jul,22,2009

TO-251 Tube/TO-252 Tape and Reel Data

TO-251 Tube

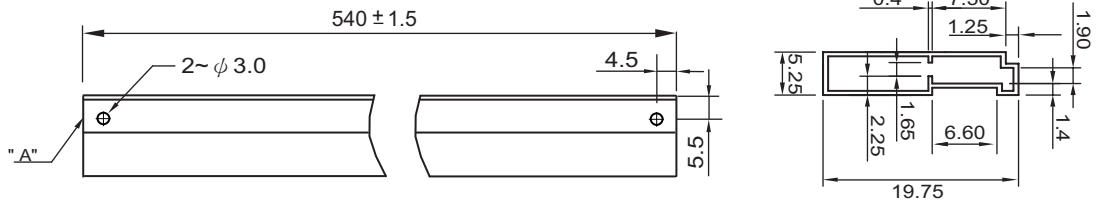

TO-252 Carrier Tape

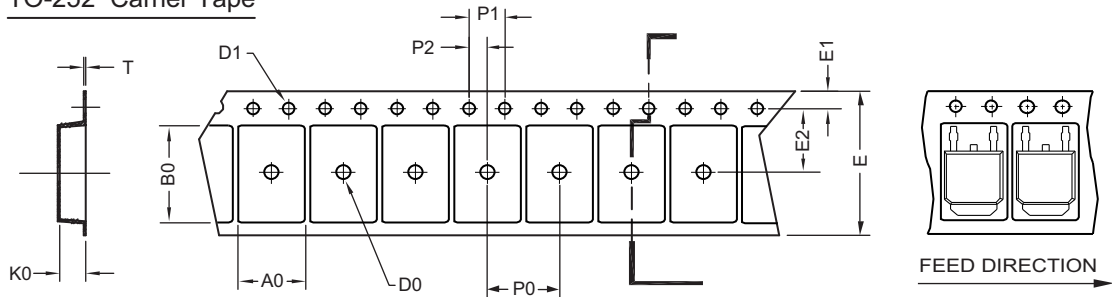

UNIT:mm

PACKAGE	A0	B0	K0	D0	D1	E	E1	E2	P0	P1	P2	T
TO-252 (16 mm)	6.96 ±0.1	10.49 ±0.1	2.79 ±0.1	φ2	φ1.5 +0.1 -0	16.0 ±0.3	1.75 ±0.1	7.5 ±0.15	8.0 ±0.1	4.0 ±0.1	2.0 ±0.15	0.3 ±0.05

TO-252 Reel

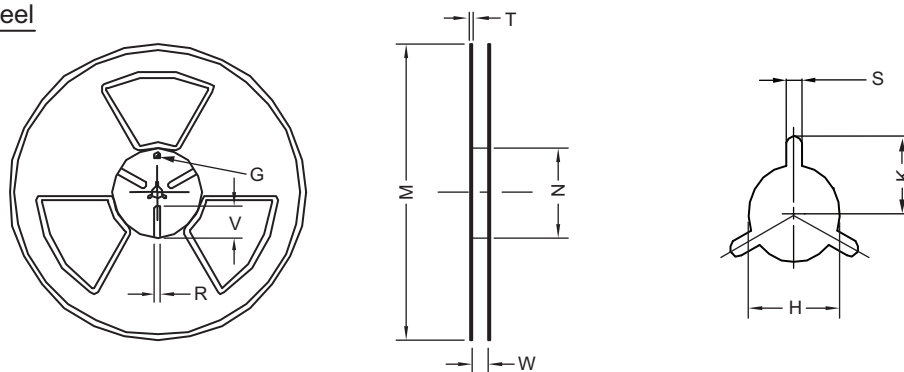

UNIT:mm

TAPE SIZE	REEL SIZE	M	N	W	T	H	K	S	G	R	V
16 mm	φ 330	φ 330 ±0.5	φ 97 ±1.0	17.0 +1.5 -0	2.2	φ 13.0 +0.5 -0.2	10.6	2.0 ±0.5	---	---	---