



## N-Channel Enhancement Mode Field Effect Transistor

### PRODUCT SUMMARY

V <sub>DSS</sub>	I <sub>D</sub>	R <sub>DS(ON)</sub> (Ω) Typ
400V	1.5A	3.5 @ V <sub>GS</sub> =10V

### FEATURES

- Super high dense cell design for low R<sub>DS(ON)</sub>.
- Rugged and reliable.
- SOT-89 Package.

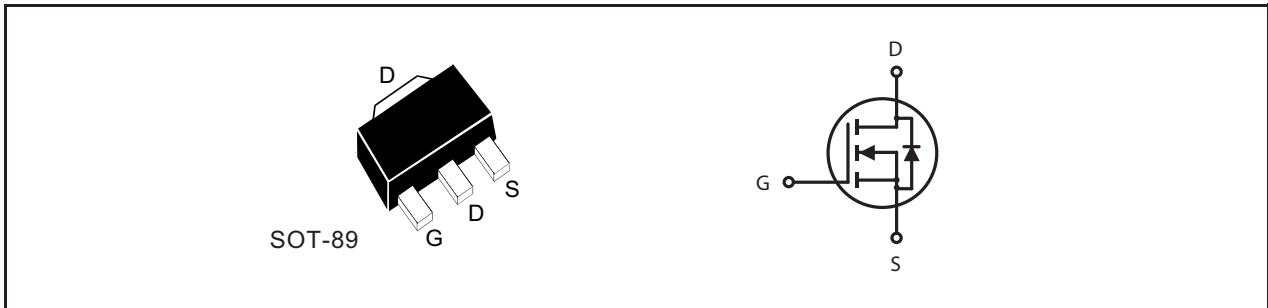

### ABSOLUTE MAXIMUM RATINGS (T<sub>A</sub>=25°C unless otherwise noted)

Symbol	Parameter	Limit	Units	
V <sub>DS</sub>	Drain-Source Voltage	400	V	
V <sub>GS</sub>	Gate-Source Voltage	±30	V	
I <sub>D</sub>	Drain Current-Continuous <sup>a</sup>	T <sub>A</sub> =25°C	1.5	A
		T <sub>A</sub> =70°C	1.2	A
I <sub>DM</sub>	-Pulsed <sup>b</sup>	6	A	
E <sub>AS</sub>	Single Pulse Avalanche Energy <sup>d</sup>	10.4	mJ	
P <sub>D</sub>	Maximum Power Dissipation	T <sub>A</sub> =25°C	1.25	W
		T <sub>A</sub> =70°C	0.8	W
T <sub>J</sub> , T <sub>STG</sub>	Operating Junction and Storage Temperature Range	-55 to 150	°C	

### THERMAL CHARACTERISTICS

Symbol	Parameter	Limit	Units
R <sub>θJA</sub>	Thermal Resistance, Junction-to-Ambient	100	°C/W

# SDK03N04

Ver 1.2

## ELECTRICAL CHARACTERISTICS (T<sub>A</sub>=25°C unless otherwise noted)

Symbol	Parameter	Conditions	Min	Typ	Max	Units
<b>OFF CHARACTERISTICS</b>						
BV <sub>DSS</sub>	Drain-Source Breakdown Voltage	V <sub>GS</sub> =0V, I <sub>D</sub> =250μA	400			V
I <sub>DSS</sub>	Zero Gate Voltage Drain Current	V <sub>DS</sub> =320V, V <sub>GS</sub> =0V			1	μA
I <sub>GSS</sub>	Gate-Body Leakage Current	V <sub>GS</sub> = ±30V, V <sub>DS</sub> =0V			±100	nA
<b>ON CHARACTERISTICS</b>						
V <sub>GS(th)</sub>	Gate Threshold Voltage	V <sub>DS</sub> =V <sub>GS</sub> , I <sub>D</sub> =250μA	2	2.9	4	V
R <sub>DS(ON)</sub>	Drain-Source On-State Resistance	V <sub>GS</sub> =10V, I <sub>D</sub> =1A		3.5	4.0	m ohm
g <sub>FS</sub>	Forward Transconductance	V <sub>DS</sub> =10V, I <sub>D</sub> =1A		0.7		S
<b>DYNAMIC CHARACTERISTICS <sup>c</sup></b>						
C <sub>ISS</sub>	Input Capacitance	V <sub>DS</sub> =25V, V <sub>GS</sub> =0V f=1.0MHz		186		pF
C <sub>OSS</sub>	Output Capacitance			38		pF
C <sub>RSS</sub>	Reverse Transfer Capacitance			7		pF
<b>SWITCHING CHARACTERISTICS <sup>c</sup></b>						
t <sub>D(ON)</sub>	Turn-On Delay Time	V <sub>DD</sub> =200V I <sub>D</sub> =1A V <sub>GS</sub> =10V R <sub>GEN</sub> =25 ohm		13		ns
t <sub>r</sub>	Rise Time			27		ns
t <sub>D(OFF)</sub>	Turn-Off Delay Time			55		ns
t <sub>f</sub>	Fall Time			128		ns
Q <sub>g</sub>	Total Gate Charge	V <sub>DS</sub> =200V, I <sub>D</sub> =1A, V <sub>GS</sub> =10V		6		nC
Q <sub>gs</sub>	Gate-Source Charge	V <sub>DS</sub> =200V, I <sub>D</sub> =1A, V <sub>GS</sub> =10V		1.9		nC
Q <sub>gd</sub>	Gate-Drain Charge			2		nC
<b>DRAIN-SOURCE DIODE CHARACTERISTICS AND MAXIMUM RATINGS</b>						
I <sub>S</sub>	Maximum Continuous Drain-Source Diode Forward Current				1	A
V <sub>SD</sub>	Diode Forward Voltage	V <sub>GS</sub> =0V, I <sub>S</sub> =1A		0.81	1.4	V

### Notes

- Surface Mounted on FR4 Board, t ≤ 10sec.
- Pulse Test: Pulse Width ≤ 300us, Duty Cycle ≤ 2%.
- Guaranteed by design, not subject to production testing.
- Starting T<sub>J</sub>=25°C, L=1mH, R<sub>G</sub>=25Ω, V<sub>DD</sub> = 50V. (See Figure 12)

Oct,08,2010

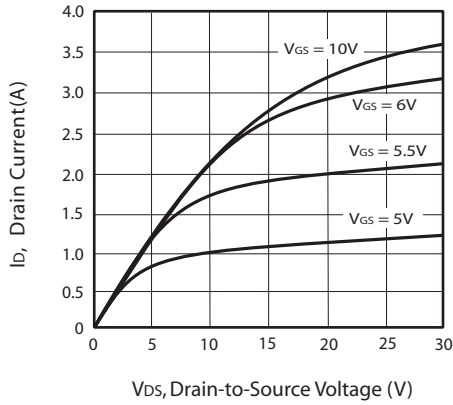

Figure 1. Output Characteristics

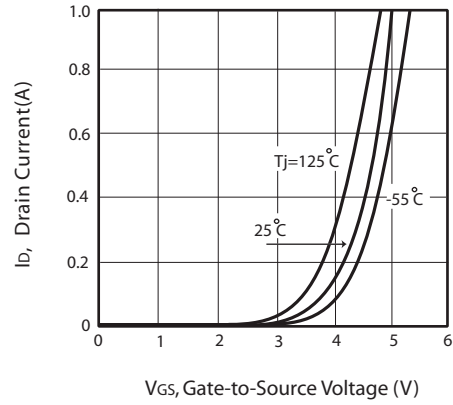

Figure 2. Transfer Characteristics

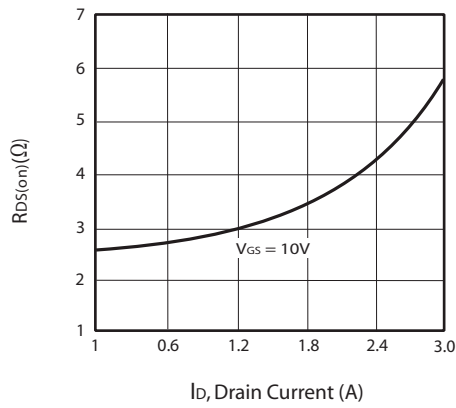

Figure 3. On-Resistance vs. Drain Current and Gate Voltage

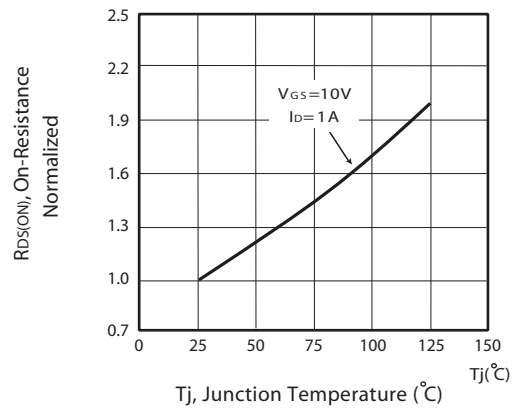

Figure 4. On-Resistance Variation with Drain Current and Temperature

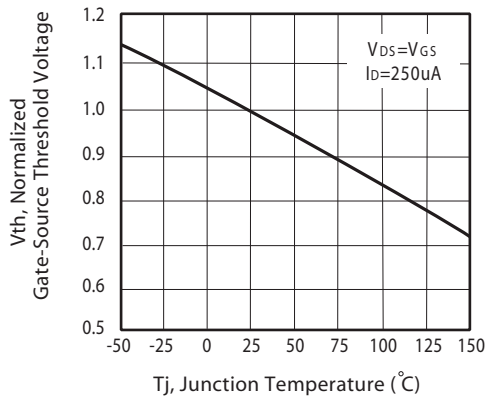

Figure 5. Gate Threshold Variation with Temperature

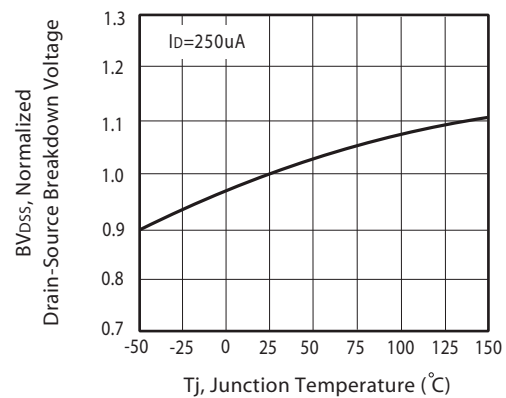

Figure 6. Breakdown Voltage Variation with Temperature

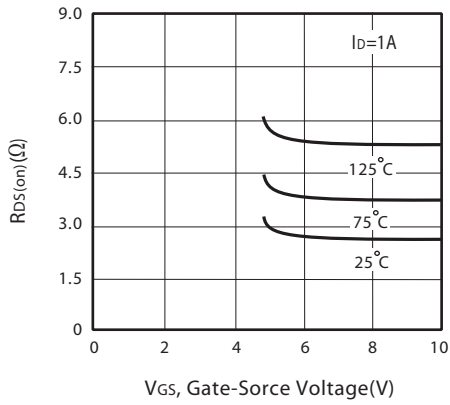

Figure 7. On-Resistance vs. Gate-Source Voltage

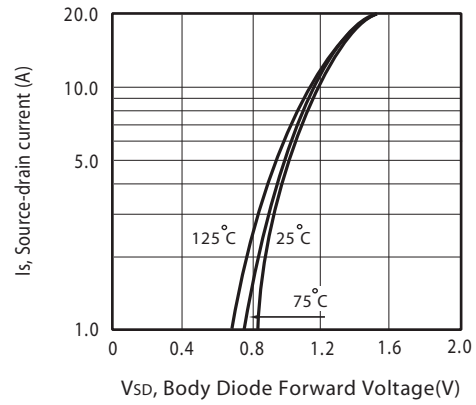

Figure 8. Body Diode Forward Voltage Variation with Source Current

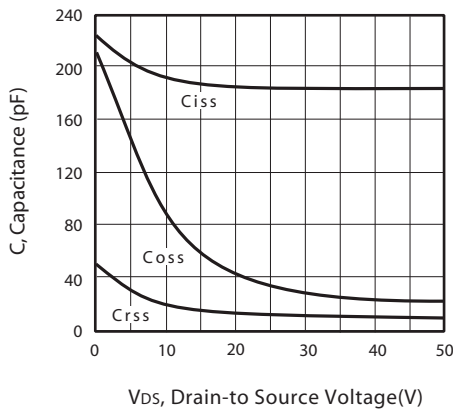

Figure 9. Capacitance

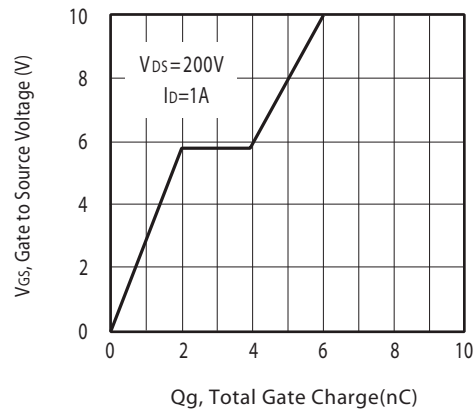

Figure 10. Gate Charge

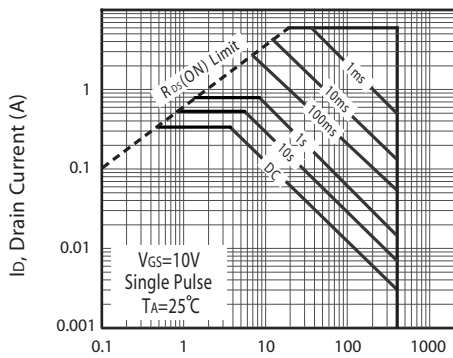
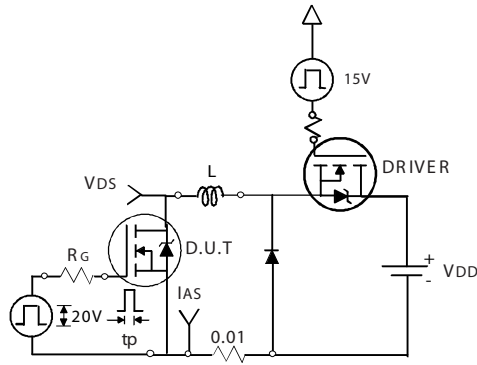
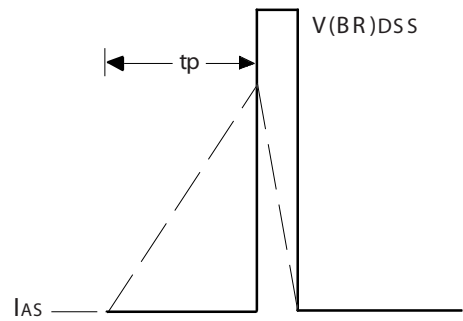

Figure 11. Maximum Safe Operating Area



Unclamped Inductive Test Circuit

Figure 12a.



Unclamped Inductive Waveforms

Figure 12b.

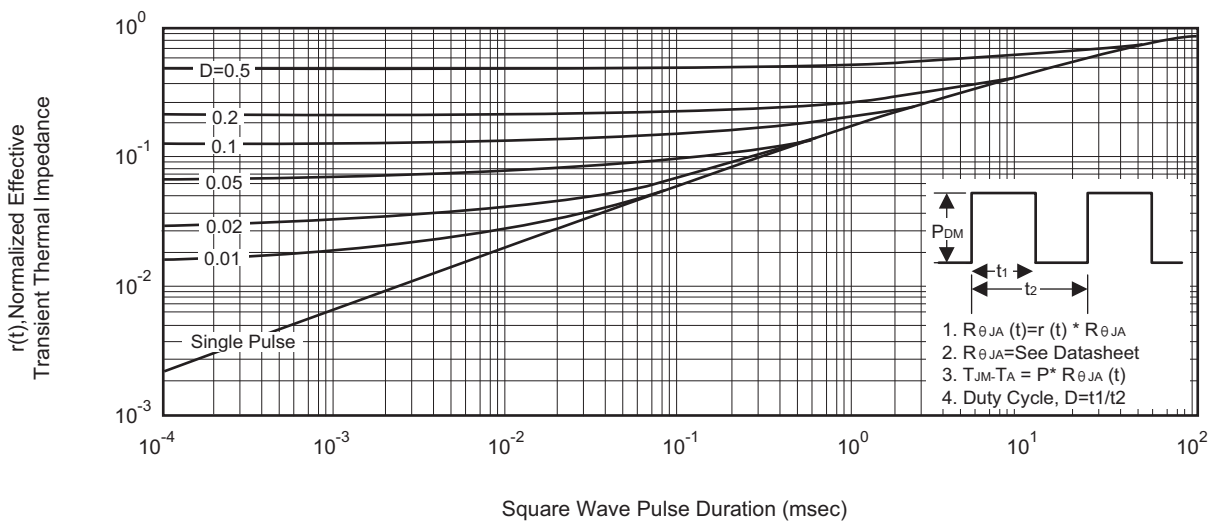
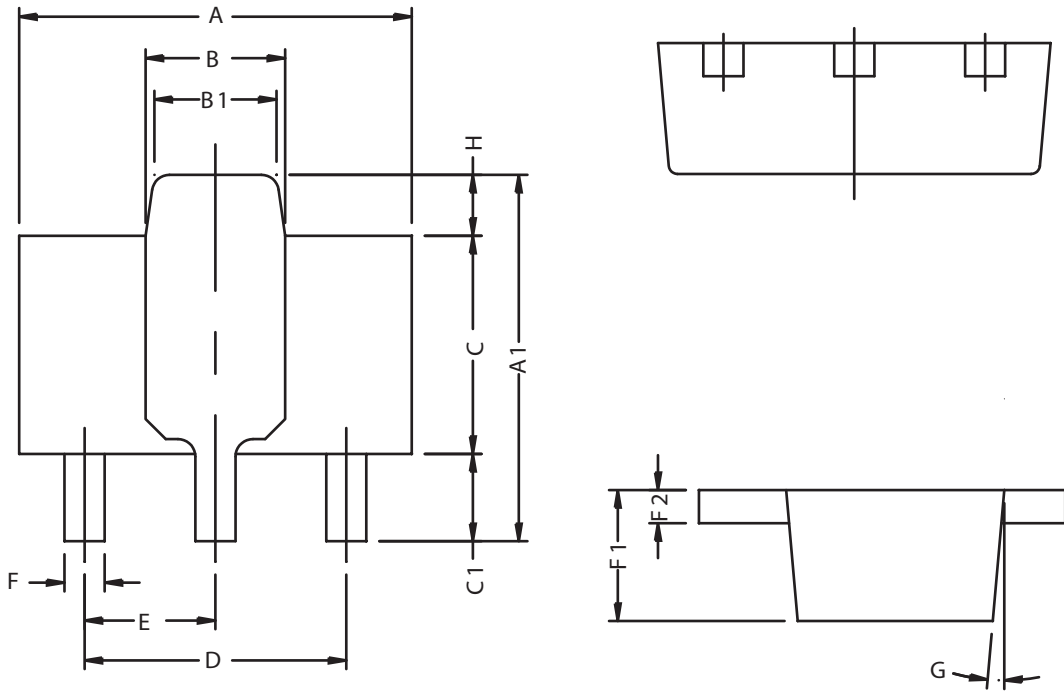

Figure 13. Normalized Thermal Transient Impedance Curve

## PACKAGE OUTLINE DIMENSIONS

### SOT-89



REF.	DIMENSIONS	
	Millimeters	
	MIN.	MAX.
A	4.40	4.60
A1	4.05	4.25
B	1.50	1.70
B1	1.30	1.50
C	2.40	2.60
C1	0.89	1.20
D	3.00 REF.	
E	1.50 REF.	
F	0.40	0.52
F1	1.40	1.60
F2	0.35	0.41
G	5° TYP.	
H	0.70 REF.	

